



Terminals
x86 performance
in monitor format



the rugged world of IT®

Terminals – PC compatible, slim, robust and well designed. These are the features ads-tec terminals have delivered for several generations. Specifically created for the rough environmental conditions of industrial everyday work, ads-tec terminals reliably work onboard forklift trucks and vehicles, as well as on production lines and machines.

VMT5000 series



VMT6000 series



VMT5000 series



VMT5010



VMT5012



VMT5015



VMT5017

VMT5000 series **Well proven thousands of times**

- Monitor sizes: 10.4", 12.1", 15" and 17" widescreen
- Five front keys for comfortable control
- 5-wire industrial touchscreen
- Brushed aluminium front panel (anodised)
- Robust aluminium diecast case
- adsX Intel® Pentium® M processor platform
- Without fans
- External WLAN antennas
- Front USB (can be disabled by software)
- Ethernet 10/100 RJ 45
- Interface connections well protected underneath a cover
- IP 65
- Complies with requirements acc. to MIL-STD 810F, figure 514.5C (US highway truck transportation)

adsX technology **High tech made in Germany**

- Use of components listed on the "long-term roadmaps" of microchip manufacturers
- Many years of system reliability
- 100 % inhouse development ensures 100 % support
- Soldered processors instead of using sockets
- Scalable processor performance based on Intel® Pentium® M platform

adsXinside



VMT6000 series

HIGHLIGHTS

- Low power Intel® Atom™
- Dual Ethernet 10/100/1000 Mbit
- Internal antennas
- Simple battery/flash access with VMT6008



VMT6008



VMT6012



VMT6015

VMT6000 series Well proven, even further advanced

- Monitor sizes: 8" widescreen, 12.1" and 15"
- Five front keys for comfortable control
- 5-wire industrial touchscreen
- Front panel from glass fibre reinforced plastic (painted)
- Robust aluminium diecast case
- adsX² Intel® Atom™ processor platform
- Low power design
- Without fans
- Internal WLAN/UMTS*/RFID** antennas
- Front USB (can be disabled by software)
- Double 10/100/1000 RJ 45 Ethernet connection
- Interface connections well protected underneath a cover
- Extended temperature range
- IP 65
- Complies with requirements acc. to EN 60721-3-5 (terrestrial vehicles) Class 5M3 incl. Flash SSD, class 5M2 incl. hard disk
- Complies with requirements acc. to MIL-STD 810F, figure 514.5C (US highway truck transportation)



adsX² technology High tech made in Germany

- Use of components listed on the "long-term roadmaps" of microchip manufacturers
- Many years of system reliability
- 100 % inhouse development ensures 100 % support
- Intel® Atom™ processor technology
- Soldered processors instead of using sockets

adsX²inside



VMT product benefits

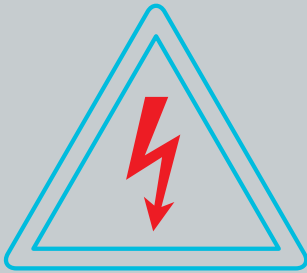

Write Filter & Faststart XP Rescue team for your file system

- Avoids the file system becoming corrupted after improper use or in the event of power failure
- Authorised people can make changes using password protection

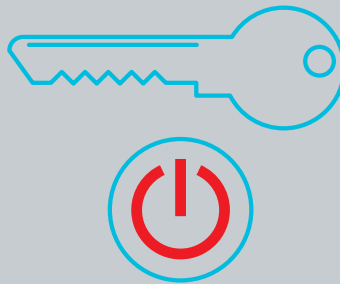

Ignition function A bright spark of an idea

When installed on board vehicles:

- Switch on together with the ignition
- System is blocked when the ignition key is removed
- Automatic terminal shutdown after expiry of an adjustable timer
- Security when leaving the vehicle
- Work can quickly be resumed after a break

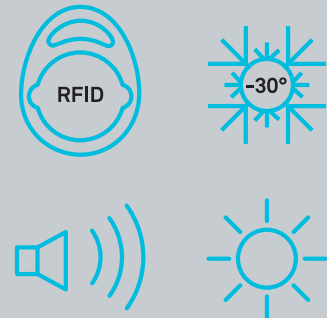

Versatile Configurations for every individual case

- RFID reader for user recognition*
- Heater for use in freezer temperature range down to $-30\text{ }^{\circ}\text{C}$
- Automatic* or manual brightness control
- Integrated speakers as acoustic signal transmitters



Green IT Makes double sense

- Zero power management (minimised battery discharge in idle state)
- Low power and ultra low power design

Operating systems The basis of your applications

- Windows® CE 6.0* or Windows® CE 5.0** or Windows® XP embedded as a platform for terminal solutions based on flash memories
- Windows® XP Professional as an open platform on hard disk
- Linux on request

Windows® CE 6.0* One image for all

- A single image for thin clients and open applications
- Display resolution and language configuration (German and English) possible



Front keys Simply good

- Five front keys for comfortable control
- Soft keyboard activation
- Task switching per toggle key
- Programmable hotkey
- Right mouse key
- FN key for setting display brightness and volume per toggle key

Front USB Just handy

- For servicing or connection of external peripherals
- Can be disabled by a software controlled USB lock



Connections Securely connected

- Strain relief for all cables
- 5V power supply for connecting an external scanner selectable via switch*

Power supply Power is needed

- ATX extended range power supply
- Terminal automatically switches into a »Soft off state« if it hasn't been used for a long time
- Voltage fluctuations in vehicles are compensated

WLAN antennas Together they are strong

- WLAN module incl. diversity function for an optimised reception
- WLAN standards: 802.11 a*/b/g
- External antenna output for connecting a roof antenna*
- Antennas are integrated in the front panel in order to prevent destruction or theft*

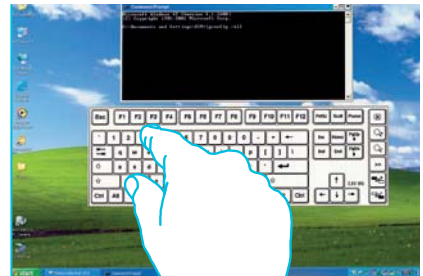

Soft keyboard Input the easy way

- The soft keyboard is available as early as during login
- You can switch between a full keyboard and a representation optimised for terminal emulations
- Size and included functions can simply be adapted depending on the application and requirements; both a numeric block as well as an alphanumeric keyboard can either be displayed individually or combined
- Automatic storage of most recently used settings when closing the soft keyboard
- Different languages and/or matching keyboard layouts, selectable depending on the operating systems used
- Additional setup options for colour adaptation or transparent mode
- API interface for controlling the keyboard from a customer application



Design Can withstand anything

- Robust aluminium diecast case
- IP 65
- Without fans
- Front panel made from glass fibre reinforced polyamide* or anodised aluminium**
- Design insensitive to vibrations

* VMT6000 series only ** VMT5000 series only

VMT brackets

Brackets **Solid from the base up**

- Different brackets are available for use at different points of installation
- All adapters are made from robust stainless steel and are wear proof
- Terminals can comfortably and safely be arrested in a large variety of inclination angles by using Nord-Lock bolts
- More bracket versions are available on request



Bracket for Rittal® Top pivot mounting*

- Installation adapter for support arm systems on machines for installation from the top



Bracket for VESA 75 Standard*

- Installation bracket for VESA 75 compatible wall mounts and support arms



Bracket for desktop or vehicle installation*

- Installation adapter for attachment to desktops or vehicles



Angular mount left/right*

- Angular mount for attachment on desktops, vehicles or at the wall



Bracket for Rittal® Bottom pivot mounting*

- Installation adapter for monitor stands and support systems for machine installation from the bottom

VMT5000 series – technical data

Device data

	VMT5010	VMT5012	VMT5015	VMT5017
Case	Powder coated aluminium diecast case			
Front panel	Anodised aluminium			
Display	10.4" TFT	12.1" TFT	15" TFT	17" TFT WXGA+
Resolution	800 x 600 pixels	800 x 600 pixels	1024 x 768 pixels	1440 x 900 pixels
as an option		1024 x 768		
Represented colours	16.1 million at max	256k at max	16.1 million at max	256k at max
Touch	Resistive industrial touchscreen			
Processor Intel®	Celeron® M 800 MHz ULV Celeron® M 1,0 GHz ULV			
	–	Pentium® M 1.1 GHz	Pentium® M 1.1 GHz	Pentium® M 1.1 GHz
	–	–	Pentium® M 1.4 GHz	Pentium® M 1.4 GHz
RAM	512 MB to 2 GB DDR RAM			
Graphic controller	Intel® 855 GME			
Graphic memory	a maximum of 64 MB shared			
Mass storage device	1 x CompactFlash® slot Alternative: 2.5" automotive hard disk with a minimum of 40 GB (UDMA)			
Interfaces	COM 1 (RS232) 1 x PS/2 mouse 1 x PS/2 keyboard 2 x USB 2.0* As an option: 1 x USB 2.0* integrated in front panel Line Out As an option: Keyboard simulator			
Network	1 x Ethernet (10/100MBit) RJ 45			
Sound	Sound output via two internal speakers			
Radio	As an option: Integrated WLAN 802.11 (b/g) module incl. diversity antennas			
Power adapter	24 V DC +/- 20% (19 to 29 V)			
Operating system	Windows® CE 5.0 or Windows® XP embedded as a platform for terminal solutions based on CompactFlash® Windows® XP Professional as an open platform on hard disk			
Protection class	IP 65			
Operating temperature	–20 to +45 °C			0 to +40 °C
Dimensions (W x H x D)	295 x 232 x 73 mm	332 x 255 x 68 mm	395 x 292 x 74 mm	460 x 302 x 82 mm
Weight	Approx. 2.5 kg	Approx. 3.0 kg	Approx. 4.8 kg	Approx. 5.2 kg
Vibration resistance	DIN EN 60068-2-6 MIL-STD 810F (01.2000), annex C., figure 514.5C (US highway truck transportation)			
Shock resistance	DIN EN 60068-2-27			
Humidity	10 to 85% without condensation			

Accessories

Brackets	As an option, different installation adapters are available for different types of applications
Keyboard trays	As an option, keyboard trays of different sizes are available for external keyboards
Power adapter	Desktop power adapter for converting 230 V AC in 24 V DC
Cable installation kits	Grommets for different diameters of cables
Connecting cables	Cable set for connecting the device with forklifts

* can be disabled by software

VMT6000 series – technical data

Device data

	VMT6008	VMT6012	VMT6015
Case	Powder coated aluminium diecast case		
Front panel	Fibreglass reinforced plastic, paint coated		
Display	8" TFT	12,1" TFT	15" TFT
Resolution	800 x 480 pixels	800 x 600 pixels	1024 x 768 pixels
as an option		1024 x 768 pixels	
Represented colours	16.1 million at max	256k at max	16.1 million at max
	Automatic or manual display brightness adjustment		
Touch	Resistive industrial touchscreen		
Processor	Intel® Atom™ 1.1 GHz	Intel® Atom™ 1.1 GHz or 1.6 GHz	
RAM	1 GB or 2 GB DDR2 RAM		
Graphic controller	Intel® SCH US15W incl. integrated graphic controller		
Graphic memory	a maximum of 8 MB, shared		
Mass storage device	2 x Flash SSD (via internal USB connections)	1 x Flash SSD (via internal USB connection) Alternative: 2.5" automotive hard disk with a minimum of 40 GB (UDMA)**	
Interfaces	COM 1 (RS232, 5 V power supply for scanner can be enabled) 1 x PS/2 (keyboard /mouse) 2 x USB 2.0* (can be disabled by software) 1 x USB 2.0* integrated in front panel (can be disabled by software) As an option: Keyboard simulator		
Network	2 x Ethernet (10/100/1000MBit) RJ 45		
Sound	Sound output via two internal speakers		
Radio	As an option: Integrated WLAN 802.11 (a/b/g) module incl. diversity antennas As an option: Connection for an external antenna		
RFID	-	As an option: Mifare® reader 13.56 MHz for ISO 14443 A, Mifare® class and Mifare® PRO boards	
Power adapter	24 V DC +/- 20% (19 to 29 V)		
Operating system	Windows® CE 6.0, Windows® XP embedded or Linux embedded as a platform for Terminal solutions based on Flash SSD Windows® XP Professional or Linux as an open platform on hard disk		
Protection class	IP 65		
Operating temperature	-20 to +55 °C		
Dimensions (W x H x D)	254 x 182 x 62 mm	338 x 261 x 62 mm	400 x 305 x 65 mm
Weight	Approx. 2.1 kg	Approx. 3.3 kg	Approx. 4.3 kg
Vibration and shock resistance	EN 60721-3-5 (06.1998), class 5M3** (terrestrial vehicles), 5h of noise type vibrations; 3.6g rms and 30g peak value MIL-STD 810F (01.2000) annex C., figure 514.5C (US highway truck transportation)		
Humidity	10 to 85% without condensation		

Accessories

Brackets	As an option, different installation adapters are available for different types of applications
Keyboard trays	As an option, keyboard trays of different sizes are available for external keyboards
Power adapter	Desktop power adapter for converting 230 V AC in 24 V DC
Cable installation kits	Grommets for different diameters of cables
Connecting cables	Cable set for connecting the device with forklifts

* All external USB interfaces are equipped as High Current type interfaces for up to 1A ** Hard disk version: Vibration/shock resistance acc. to class 5M2

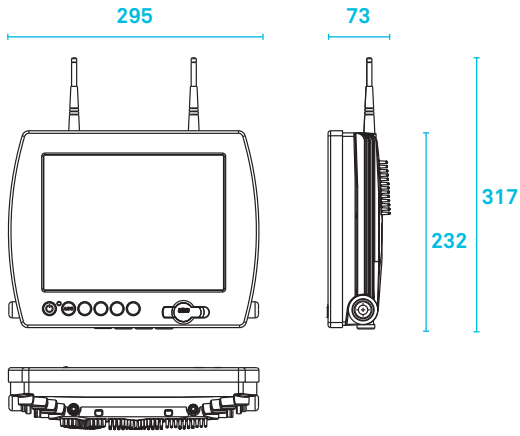

VMT5010

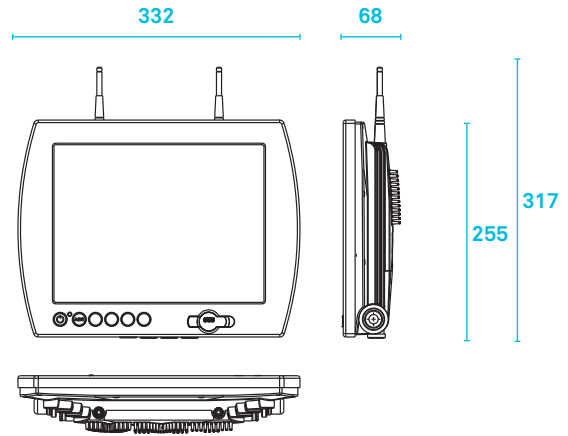

VMT5012

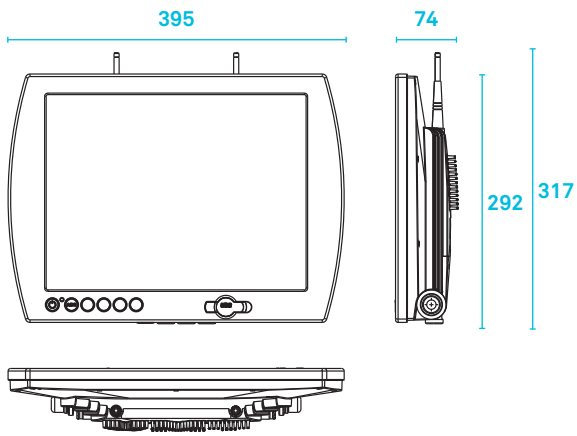

VMT5015

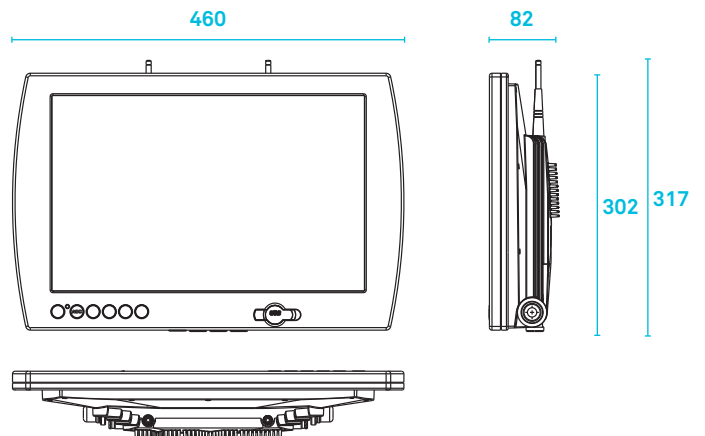

VMT5017

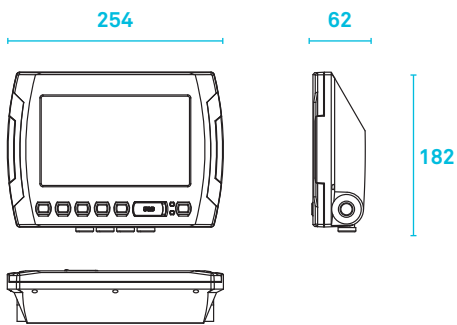

VMT6008

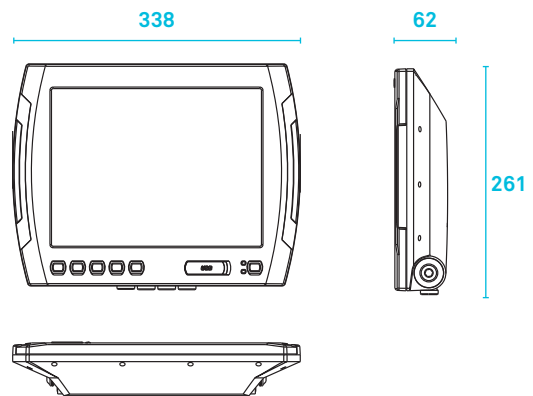

VMT6012

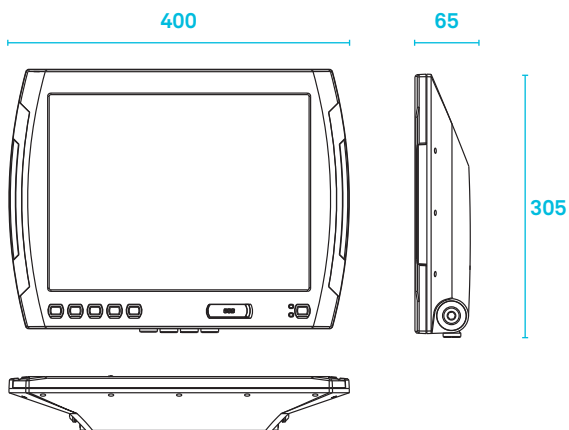

VMT6015

Scalable Optimised for your application

- Different display sizes
- Choose from a variety of different storage media and processor versions
- The range of different brackets is available for all VMTs

Product portfolio

Tablet PCs

IT Infrastructure

Terminals

Industrial PCs

ads-tec GmbH
Raiffeisenstraße 14
70771 Leinfelden-Echterdingen
Telefon +49 711 45894-600
Telefax +49 711 45894-992
sales@ads-tec.de
www.ads-tec.de



the rugged world of IT®